

Total solder points: 115

Difficulty level: *beginner* 1 2 3 4 5 *advanced*

BUS DIMMER FOR HOME MODULAR LIGHT SYSTEM



K8037

“ PLUG - IN ” module for use
with home modular lights
system K8006.

This dimmer is a plug-in module for our K8006 home lighting system. Just like its predecessor K8007, it was designed for the dimming of conventional incandescent lamps and halogen lighting. Not only is this kit easy to operate with just one push button, it is also equipped with numerous safety features. With low-voltage halogen lighting the transformation from mains voltage to 12V lamp voltage is to be achieved by means of a wire-wound transformer. You can use both a toroidal and an encapsulated transformer. Most electronic transformers are incompatible with this dimmer.

Specifications:

- ☑ Dimmer for our K8006 home lighting system.
- ☑ Suitable for incandescent lamps, mains voltage halogen lighting and low voltage halogen lighting in combination with a conventional (wire wound) transformer.
- ☑ Easy push-button operation
- ☑ A brief push toggles on/off, while continued pushing engages the dimming function
- ☑ Non volatile memory for last light intensity setting.
- ☑ Lots of safety features to protect lamp life e.g. “soft-start” function and automatic deactivation after 12 hours or after 20 min of operation at insufficient light intensity...
- ☑ Transformer protection in case of defective light sources.
- ☑ LED status indication.

Features:

- Suppression of radio & TV interference according to EN55015.
- Operating voltages: 110-125V or 230-240V AC (50/60Hz)
- Max. load: 350W/230V or 170W/115V
- Max. phase shift with inductive load: 30°.
- Dimming speed: +/- 5 sec.
- PCB dimensions: 65 x 57 x 25mm.

1. Assembly (Skipping this can lead to troubles !)

Ok, so we have your attention. These hints will help you to make this project successful. Read them carefully.

1.1 Make sure you have the right tools:

- A good quality soldering iron (25-40W) with a small tip.
- Wipe it often on a wet sponge or cloth, to keep it clean; then apply solder to the tip, to give it a wet look. This is called 'thinning' and will protect the tip, and enables you to make good connections. When solder rolls off the tip, it needs cleaning.
- Thin raisin-core solder. Do not use any flux or grease.
- A diagonal cutter to trim excess wires. To avoid injury when cutting excess leads, hold the lead so they cannot fly towards the eyes.
- Needle nose pliers, for bending leads, or to hold components in place.
- Small blade and Phillips screwdrivers. A basic range is fine.

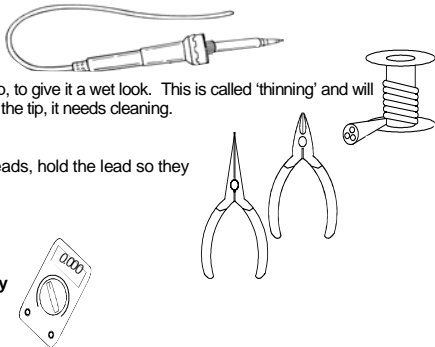

For some projects, a basic multi-meter is required, or might be handy

1.2 Assembly Hints :

- ⇒ Make sure the skill level matches your experience, to avoid disappointments.
- ⇒ Follow the instructions carefully. Read and understand the entire step before you perform each operation.
- ⇒ Perform the assembly in the correct order as stated in this manual
- ⇒ Position all parts on the PCB (Printed Circuit Board) as shown on the drawings.
- ⇒ Values on the circuit diagram are subject to changes.
- ⇒ Values in this assembly guide are correct*
- ⇒ Use the check-boxes to mark your progress.
- ⇒ Please read the included information on safety and customer service

* Typographical inaccuracies excluded. Always look for possible last minute manual updates, indicated as 'NOTE' on a separate leaflet.

1.3 Soldering Hints :

1- Mount the component against the PCB surface and carefully solder the leads

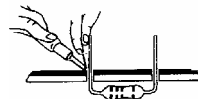

2- Make sure the solder joints are cone-shaped and shiny

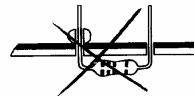
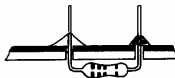

3- Trim excess leads as close as possible to the solder joint

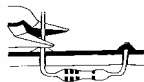

REMOVE THEM FROM THE TAPE ONE AT A TIME !

AXIAL COMPONENTS ARE TAPED IN THE CORRECT MOUNTING SEQUENCE !

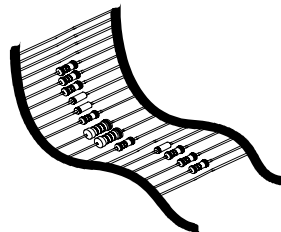

1. Jumper

J : 5X

Make sure that the jumpers are mounted close to the PCB!

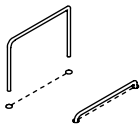

2. Diodes. Watch the polarity !

D1 : 1N4007
 D2 : 1N4148
 D3 : 1N4148

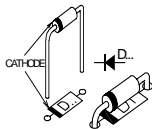

3. Zenerdiodes. Watch the polarity !

ZD1 : 12V0
 ZD2 : 4V7
 ZD3 : 4V7

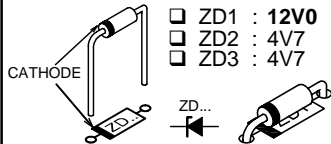

4. Metal film resistor

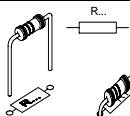

R1 : 47 (4 - 7 - 0 - B - 9)

5. Resistor

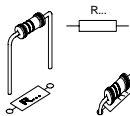

R2 : 390 (3 - 9 - 1 - B)

6. IC socket, watch the position of the notch !

IC1 : 14P

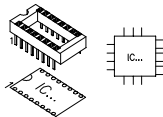

7. Capacitors.

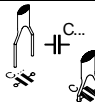

C1 : 100nF (104)
 C2 : 100nF (104)
 C3 : 10nF (103)
 C4 : 10nF (103)
 C5 : 10nF (103)
 C6 : 15pF (15)
 C7 : 15pF (15)

8. LEDs. Watch the polarity !

LD1 : Red
 LD2 : Yellow

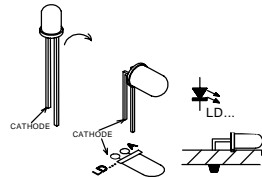

9. Transistors.

- T1 : BC547B
- T2 : BC547B

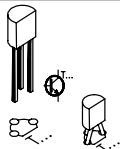

10. Pin headers

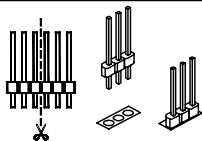

- JP1 : 3 pins
- JP2 : 3 pins
- JP3 : 3 pins

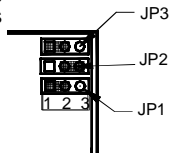

11. Vertical resistors

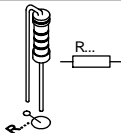

- R3 : 100K (1 - 0 - 4 - B)
- R4 : 470K (4 - 7 - 4 - B - 9)
- R5 : 470K (4 - 7 - 4 - B - 9)
- R6 : 1M (1 - 0 - 5 - B - 9)
- R7 : 100K (1 - 0 - 4 - B)
- R8 : 1K5 (1 - 5 - 2 - B)
- R9 : 1K5 (1 - 5 - 2 - B)
- R10 : 220 (2 - 2 - 1 - B - 9)
- R11 : 3K9 (3 - 9 - 2 - B)
- R12 : 3K9 (3 - 9 - 2 - B)
- R13 : 3K9 (3 - 9 - 2 - B)

R4 ... R6 & R10 are metal film resistors.

12. Capacitor

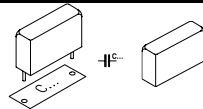

- C10 : 100nF/250VAC

13. Electrolytic Capacitors. Watch the polarity !

- C8 : 100µF
- C9 : 220µF

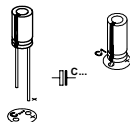

14. 1W resistors

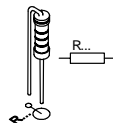

- R14 : 220 (2 - 2 - 1 - B)

15. Quartz crystal

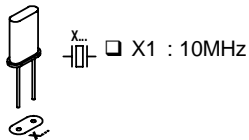

16. Triac

□ TR1 : TIC225M

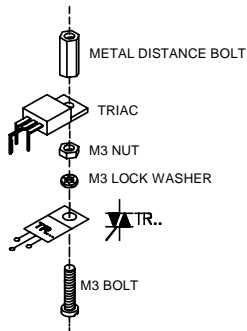

17. Capacitor

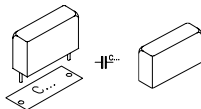

Choose operating voltage :

For 110 - 125VAC :

□ C11 : 1 μ F / 250V

For 220 - 240VAC :

□ C11 : 0,47 μ F / 630V

18. Coil.

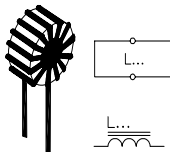

□ L1 : 1mH / 2,5A

19. IC, Check the position of the notch!

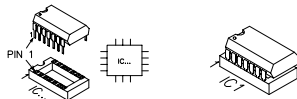

□ IC1 : VK8037
programmed PIC16F630 - I/P



**CHECK THOROUGHLY ALL
THE COMPONENTS FOR MISS
MOUNTING, INCLUDING SOL-
DERING ERRORS.**

20. Installation & use

- Cut off the mains voltage of the K8006 (deactivate the main fuse of your switch box).
- Mount the jumpers in locations JP1,2, 3. (see fig. 1.0) to select the settings (see page 12).

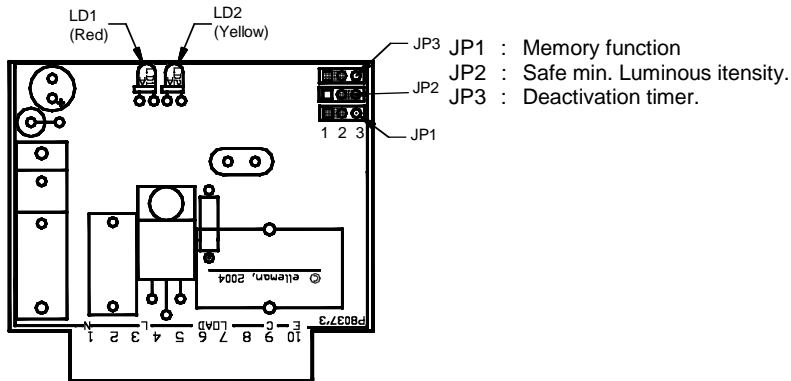

- Place the K8037 module into a free connector.
- Connect a load suitable for the specifications of this module !

You can now activate your K8006

When you start up your K8037, LD1 & LD2 will flash together for a couple of seconds until the self-test is completed. The indication LEDs display any irregularity the CPU may discover (read "LED indication in case of error" below). Following the self-test, LD2 will flash once when the net frequency is 50Hz or twice for 60Hz.

The module is now operational.

Press an arbitrary button momentarily to activate or deactivate the light source or hold the button to adjust the luminous intensity.

LED indications in case of normal operation:

LD2 (yellow LED):

- ✔ Flashes once every 5 seconds when the module is in standby mode (lamp OFF).
- ✔ Flashes slowly (2x/sec) when the lamp is burning, but not at full luminous intensity.
- ✔ Stays ON when max. luminous intensity has been reached.
- ✔ Flashes very quickly (10x/sec) while the luminous intensity is being adjusted.

LD1 (red LED):

- ✔ Flashes slowly together with LD2 (yellow LED) if the luminous intensity is too low. This only happens with JP3 in the '2-3' position.

LED indications in case of error:

When the CPU detects an error, LD1 (red) can provide an indication as to the nature of the problem. LD2 (yellow) will then remain lit continuously, whereas LD1 (red) will repeatedly flash a number of times:

We advise you to briefly interrupt the supply voltage and evaluate the situation. It is possible to restart the module without interrupting the voltage: hold the operation button for at least 10 seconds (until both LEDs are extinguished).

Flashes LD1	Error	Possible cause / solution
1	Timeout in the positive alternation of the mains voltage	error in voltage zero-crossing circuit (T1, ...)
2	Timeout in the negative alternation of the mains voltage	error in voltage zero-crossing circuit (T1, ...)
3	Triac triggering timeout	<ul style="list-style-type: none"> - Triac defective ? - Light source defective ? - T2 defective ? - Load doesn't conform to specifications ?
4	Phase shift is too great	<ul style="list-style-type: none"> - Load behaves too inductively ? - No load connected ? - No load on transformer (because of defective lamp ?) - Load not conform ?

21. Jumper selection

The settings of the dimmer module are determined by placing a shunt (=jumper) over pins 1-2 or 2-3 of JP1, 2 and 3 (see figure 1.0). The operation of the device becomes unstable if the jumpers are not mounted.

JP1 – Memory function:

The last used luminous intensity is stored in the memory if this function is activated.

- 1-2: Memory function is deactivated.
- or
- 2-3: Memory function is activated.

JP2 – Safe min. luminous intensity:

This function is designed to make sure a lamp doesn't burn at too low a luminous intensity for too long. This function offers two distinct advantages: first of all, the life of a halogen bulb is not shortened unnecessarily because it's working at too low a temperature. Furthermore, it doesn't really matter if a lamp escapes your notice because of its limited luminous intensity. The lamp will be extinguished automatically after a certain time.

- 1-2: This function is deactivated.
- or
- 2-3: This function is activated.

JP3 – Deactivation timer:

Lamps are automatically deactivated after \pm 12 hours of continuous use when this function is activated:

1-2: Deactivation timer is deactivated.

or

2-3: Deactivation timer is activated.

The “TP” connection on the print is only used by the people in our technical department.

22. PCB layout.

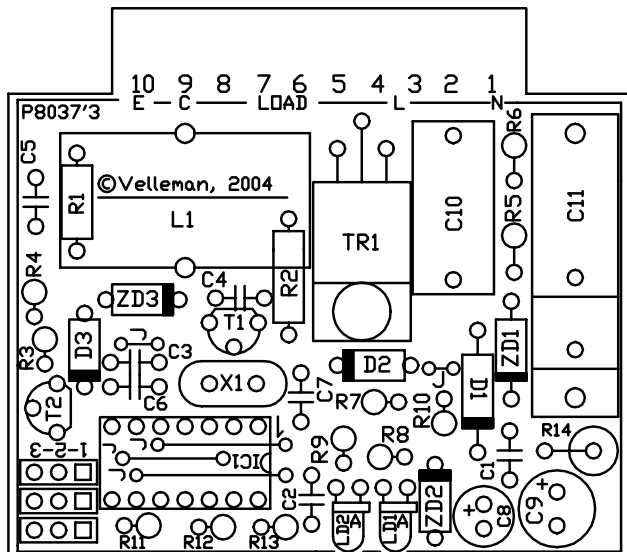

23. Diagram

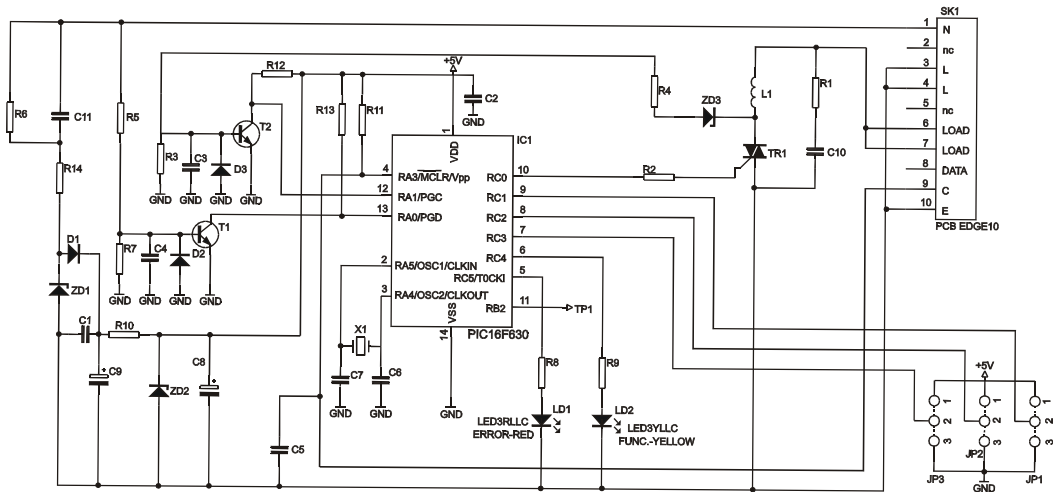



Modifications and typographical errors reserved
© Velleman Components nv.
H80371P - 2004 - ED1

